



VENEER VENT®

Rainscreen Exhaust Vent

VENEER VENT® | RAINSCREEN ACCESSORIES

DESCRIPTION

Veneer Vent® Top Vent is designed to be used at the top of the wall just under the soffit for proper convective airflow evacuation in masonry veneer applications.

A rainscreen wall system is like a car engine. In order for the engine to work effectively, there must be an intake and an exhaust. Think of Veneer Vent® as the exhaust pipe to a rainscreen wall system.

Veneer Vent® provides proper venting in wall systems that comply with the rainscreen wall recommendations as defined by the 2021 & 2024 IBC & IRC codes on plywood and OSB sheathing.

Veneer Vent® serves as a vented Casing Bead because of its 1" vent slots to manage airflow within the airspace created by the Mortairvent® rainscreen drainage & ventilation mat.

Veneer Vent® Top Vent Physical Data

Drainage & Ventilation Mat Thickness		.25"
Overall Ground	A	1-1/8"
Flange	B	2-1/4"
Drip	C	.25"
Air Channel	D	3/8"
Length	E	8'
Packaging		20 pieces per box

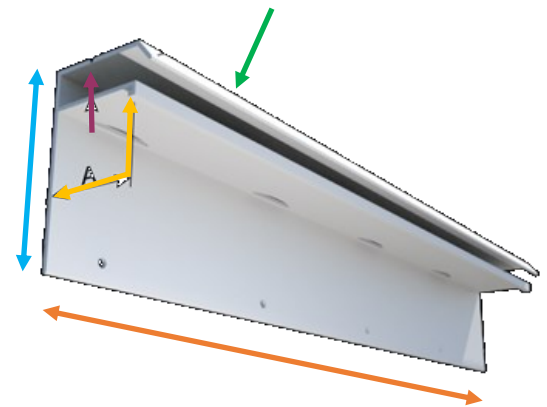

ADVANCED BUILDING PRODUCTS, INC.
 Phone: 800-252-2306 Fax: 207-490-2998
 info@abp-1.com www.advancedbuildingproducts.com

CODE APPROVALS & PERFORMANCE STANDARDS

ASTM C1063 Standard Specification for Installation of Lathing and Furring to Receive Interior and Exterior Portland Cement-Based Plaster

ASTM C1780 Standard Practice for Installation Methods for Cement-based Adhered Masonry Veneer

ASTM C1861 Standard Specification for Lathing and Furring Accessories, and Fasteners, for Interior and Exterior Portland Cement-Based Plaster

ASTM D256 Standard Test Methods for Determining the Izod Pendulum Impact Resistance of Plastics

ASTM D638 Standard Test Method for Tensile Properties of Plastics

ASTM D648 Standard Test Method for Deflection Temperature of Plastics Under Flexural Load in the Edgewise Position

ASTM D1784 Standard Classification System and Basis for Specification for Rigid Poly(Vinyl Chloride)

(PVC) Compounds and Chlorinated Poly(Vinyl Chloride) (CPVC) Compounds

ASTM D4216 Standard Specification for Rigid Poly(Vinyl Chloride) (PVC) and Related PVC and Chlorinated Poly(Vinyl Chloride) (CPVC) Building Products Compounds

ASTM E2925 Standard Specification for Manufactured Polymeric Drainage and Ventilation Materials Used to Provide a Rainscreen Function

Veneer Vent® Bottom Vent This weep screed serves as the foundation weep screed because of its 3.5" attachment flange and has drainable slots to manage moisture and allow air into the wall system behind the cladding via the entangled mesh.

Veneer Vent® Bottom Vent Physical Data

Drainage & Ventilation Mat Thickness		.25"
Overall Ground	A	1-1/8"
Flange	B	3-1/2"
Drip	C	.25"
Air Channel	D	1/4"
Length	E	8'
Packaging		20 pieces per box

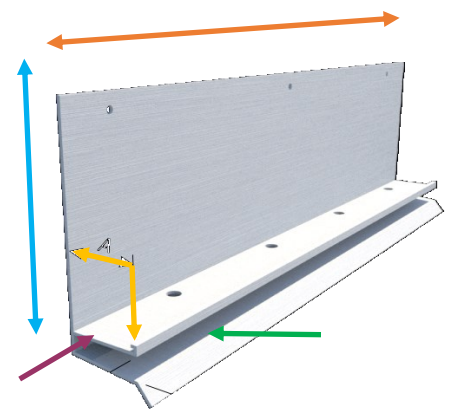

ADVANCED BUILDING PRODUCTS, INC.
 Phone: 800-252-2306 Fax: 207-490-2998
 info@abp-1.com www.advancedbuildingproducts.com